

GESTRA Steam Systems

MK 45-1



MK 45-2

MK 45 A-1

MK 45 A-2

Installation Instructions 810348-07

Steam Traps

MK 45-1, MK 45-2, MK 45 A-1, MK 45 A-2

Contents

Page

Important Notes

Usage for the intended purpose	4
Safety note	4
Danger	4
Attention	4
PED (Pressure Equipment Directive)	4
ATEX (Atmosphère Explosible)	4

Explanatory Notes

Scope of supply	5
Description	5
Function	5

Technical Data

Corrosion resistance	6
Sizing	6
Name plate / Marking	6

Design

Component parts MK 45-1, MK 45-2, MK 45 A-1, MK 45 A-2	7
Thermostatic capsule	8
Key	9

Installation

MK 45-1, MK 45-2, MK 45 A-1, MK 45 A-2	10
Flanged traps	10
Socket-weld traps	10
Screwed-socket traps	10
Butt-weld traps	11
Attention	11
Heat treatment of welds	11
Tools	11

Commissioning

MK 45-1, MK 45-2, MK 45 A-1, MK 45 A-2	11
Attention	11

Contents – continued –

Page

Operation

MK 45-1, MK 45-2, MK 45 A-1, MK 45 A-2	12
Thermostatic capsule	12

Maintenance

MK 45-1, MK 45-2, MK 45 A-1, MK 45 A-2	12
Check steam trap	12
Clean / exchange capsule and nozzle insert	12
Clean / exchange strainer	13
Tools.....	13
Torques	13

Spare Parts

MK 45-1, MK 45-2, MK 45 A-1, MK 45 A-2	14
Spare parts list	14

Decommissioning

Danger	15
Disposal	15

Important Notes

Usage for the intended purpose

Use steam traps MK 45-1, MK 45-2, MK 45 A-1 and MK 45 A-2 only for the discharge of condensed water or for air venting from steam spaces.

Use this equipment only for the discharge of condensate from steam lines within the specified pressure and temperature ratings and check the corrosion resistance and chemical suitability for the application in question.

Safety note

The equipment must only be installed and commissioned by qualified staff.

Maintenance and retrofitting must only be performed by adequately trained persons who have a recognised level of competence.



Danger

The steam trap is under pressure during operation.

When loosening flanged connections, plugs or the regulator, hot water and/or steam may escape. This presents the risk of severe scalding.

Installation and maintenance work should only be carried out when the system is depressurized (0 bar): isolate the trap from both upstream and downstream pressure.

The trap becomes hot during operation. This presents the danger of severe burns to hands and arms. Installation and maintenance work should only be carried out when the system is cold (20 °C).

Sharp edges on internal parts present a danger of cuts to hands. Always wear industrial gloves when replacing the regulator or the strainer.



Attention

The name plate indicates the technical specification of the equipment. Do not commission or operate a steam trap without a name plate.

PED (Pressure Equipment Directive)

The equipment fulfills the requirements of the Pressure Equipment Directive PED 97/23/EC.

For applications with fluids of group 2.

According to section 3.3 the equipment is excluded from the scope of this directive and must therefore not be CE marked.

ATEX (Atmosphère Explosible)

The equipment does not have its own potential source of ignition and is therefore not subject to the ATEX Directive 94/9/EC.

The equipment can be used in potentially explosive areas 0, 1, 2, 20, 21, 22 (1999/92/EC).

The equipment is not Ex marked.

Explanatory Notes

Scope of supply

MK 45-1:

1 Steam trap MK 45-1
1 Installation manual

MK 45-2:

1 Steam trap MK 45-2
1 Installation manual

MK 45 A-1:

1 Steam trap MK 45 A-1
1 Installation manual

MK 45 A-2:

1 Steam trap MK 45 A-2
1 Installation manual

Description

Thermostatic steam trap with corrosion-resistant thermostatic capsule unaffected by waterhammer. Integral Y-type strainer and non-return valve. Asbestos-free cover gasket (graphite/CrNi).

Installation in any position.

The traps with standard capsule "N" discharge condensate with virtually no banking-up, the traps with special capsule "U" with an undercooling of approx. 30 K (degC).

■ **MK 45-1 with tandem seat (double sealing)**

Particularly suitable for low condensate flowrates.

Optionally either with standard capsule "5N1" or undercooling capsule "5U1".

■ **MK 45-2 with single seat**

For larger condensate flowrates.

Optionally either with standard capsule "5N2" or undercooling capsule "5U2".

■ **MK 45 A-1 with tandem seat (double sealing)**

Particularly suitable for low condensate flowrates.

Optionally either with standard capsule "5N1" or undercooling capsule "5U1".

■ **MK 45 A-2 with single seat**

For larger condensate flowrates.

Optionally either with standard capsule "5N2" or undercooling capsule "5U2".

Function

The MK 45... is a thermostatic steam trap with membrane regulator. The capsule is filled with a liquid which boils at a temperature a few degrees lower than water. As long as condensate flows through the steam trap the liquid in the capsule is completely condensed due to the low ambient temperature. The pressure inside the capsule is lower than the surrounding pressure (service pressure) and the membrane with the valve disc is pushed in the opening direction. As the condensate temperature approaches steam temperature, the liquid filling of the capsule starts to boil and evaporate. The pressure in the capsule rises and the membrane with the valve disc is moved in the closing direction.

Automatic air-venting is provided both, during start-up and during normal operation. The correct functioning of the MK 45... is neither affected by fluctuations in the upstream pressure nor by back pressure. The MK 45... can also be used for thermal air venting.

Technical Data

Corrosion resistance

If the steam trap is used for the intended purpose, its safety is not impaired by corrosion.

Sizing

The trap body must not be subjected to pulsating loads. The dimensional allowances for corrosion and anti-corrosive additives reflect the latest state of technology.

Name plate / Marking

The pressure / temperature ratings are indicated on the trap body / the name plate.
For more information see GESTRA data sheets and Technical Information.

According to EN 19 the name plate and the valve body indicate the type and design:

- Name / logo of the manufacturer
- Type designation
- Pressure class PN or Class
- Material number
- Max. temperature
- Max. pressure
- Flow direction
- Stamp on trap body, e. g. $\frac{1}{08}$ specifies the quarter and the year of production
(Example: 1st quarter 2008).

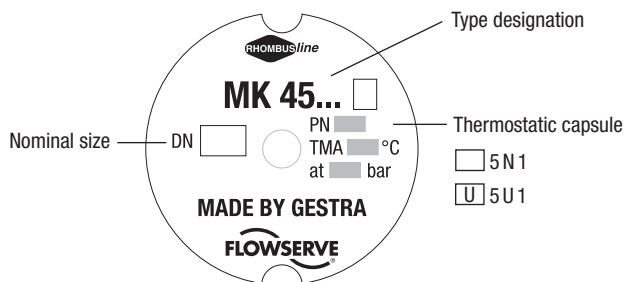

Fig. 1

Design

Component parts MK 45-1, MK 45-2, MK 45 A-1, MK 45 A-2

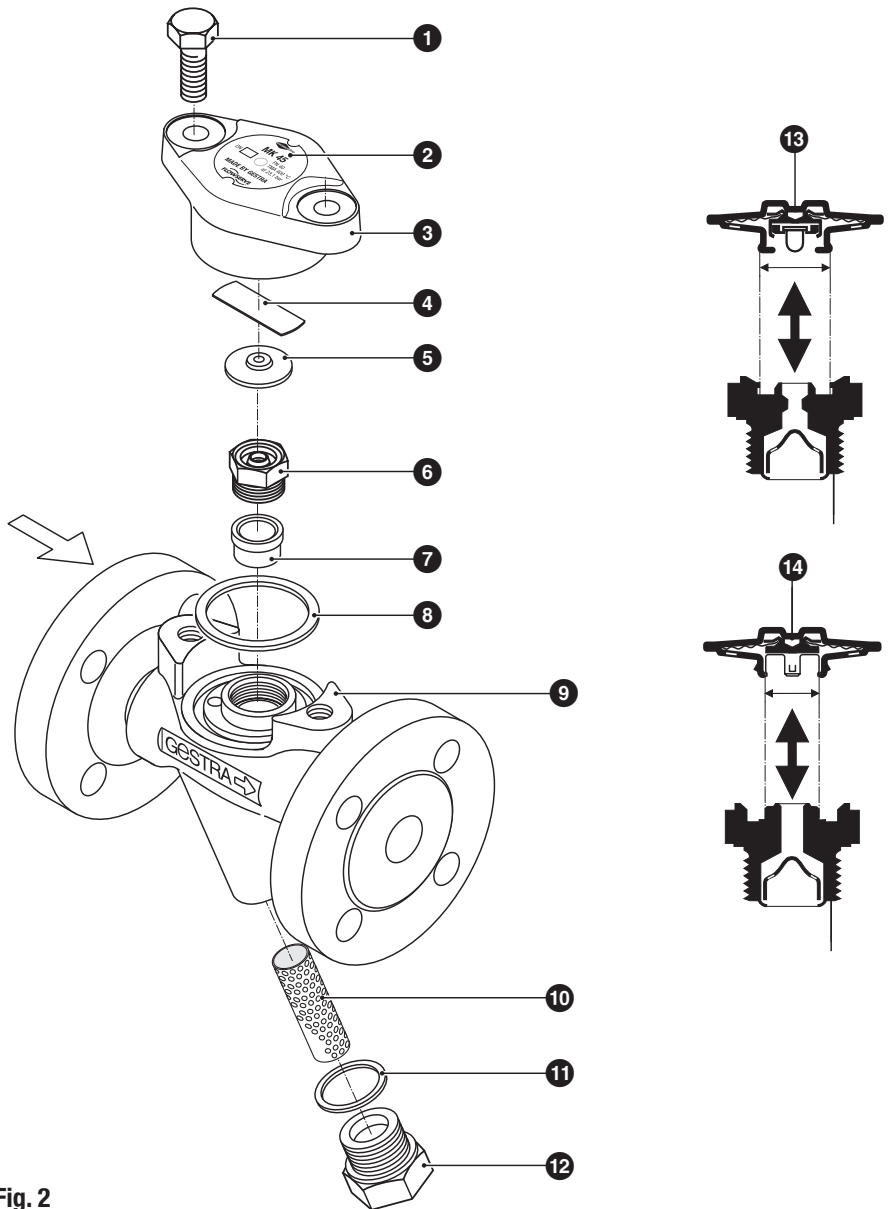

Fig. 2

Thermostatic capsule

Capsule for nozzle insert with tandem seat ⑬: 5N1, 5U1

Capsule intact

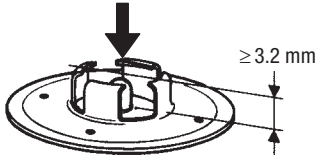

Fig. 3

Capsule defective

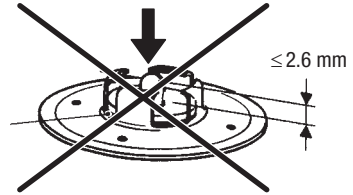

Fig. 4

Capsule for nozzle insert with single seat ⑭: 5N2, 5U2

Capsule intact

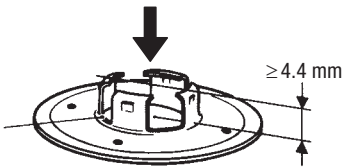

Fig. 5

Capsule defective

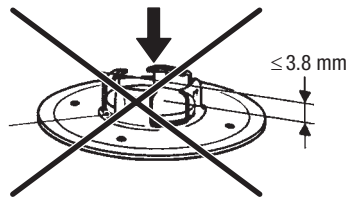

Fig. 6

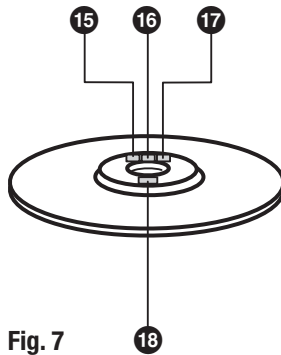

Fig. 7

Key

- 1 Hexagon-head screw M 10 x 25
- 2 Name plate
- 3 Cover
- 4 Spring
- 5 Thermostatic capsule
- 6 Nozzle insert with non-return valve action
- 7 Bush (interference-fitted, cannot be replaced)
- 8 Gasket 40 x 48 x 2
- 9 Body
- 10 Strainer
- 11 Plug gasket A 24 x 29
- 12 Plug
- 13 Capsule with nozzle insert for tandem seat
- 14 Capsule with nozzle insert for flat seat
- 15 Code number of pressure rating
 - 5 = Δp 22 bar
 - 6 = Δp 32 bar
- 16 Code letter of opening temperature
 - N = Standard, Δt approx. 10 K
 - U = Undercooling, Δt approx. 30 K
- 17 Code number of capacity
 - 1 = Low capacity
 - 2 = High capacity
- 18 Manufacturing code number

Installation

MK 45-1, MK 45-2, MK 45 A-1, MK 45 A-2

The steam traps can be installed in any position (arrow must point towards direction of flow). In the case of horizontal installation, make sure that the cover is at the top.

Flanged traps

1. Observe correct position of installation.
2. Observe direction of flow. The flow arrow is on the trap body.
3. Consider space required for opening trap. When the trap is installed a minimum space of **30 mm** is required for removing cover ③.
4. Remove plastic plugs. They are **only** used as transit protection.
5. Clean seating surfaces of both flanges.
6. Install steam trap.

Socket-weld traps

1. Observe correct position of installation.
2. Observe direction of flow. The flow arrow is on the trap body.
3. Consider space required for opening trap. When the trap is installed a minimum space of **30 mm** is required for removing the cover ③.
4. Remove plastic plugs. They are **only** used as transit protection.
5. Remove thermostatic capsule as described under **Maintenance**.
6. Clean socket-weld ends.
7. Apply arc welding processes 111 and 141 in accordance with ISO 4063.

Screwed-socket traps

1. Observe correct position of installation.
2. Observe direction of flow. The flow arrow is on the trap body.
3. Consider space required for opening trap. When the trap is installed a minimum space of **30 mm** is required for removing the cover ③.
4. Remove plastic plugs. They are **only** used as transit protection.
5. Clean thread of screwed sockets.
6. Install steam trap.

Installation – continued –

Butt-weld traps

1. Observe correct position of installation.
2. Observe direction of flow. The flow arrow is on the trap body.
3. Consider space required for opening trap. When the trap is installed a minimum space of **30 mm** is required for removing the cover ③.
4. Remove plastic plugs. They are **only** used as transit protection.
5. Clean butt-weld ends.
6. Apply arc welding processes 111 and 141 in accordance with ISO 4063 or gas welding process 3 to ISO 4063.



Attention

- Only qualified welders certified e. g. according to DIN EN 287 may weld the steam trap into pressurized lines.

Heat treatment of welds

A subsequent heat treatment of the welds is not required.

Tools

- Spanner 16 mm A.F. to DIN 3113, form B
- Spanner 22 mm A.F. to DIN 3113, form B

Commissioning

MK 45-1, MK 45-2, MK 45 A-1, MK 45 A-2

Make sure that the flanged connections of the MK 45-1, MK 45-2, MK 45 A-1 or MK 45 A-2 are permanently bolted and tight.



Attention

The steam trap is under pressure at start-up and during the operation.

The steam trap becomes hot during operation. This presents the risk of severe burns to hands and arms.

Always wear industrial gloves when setting the regulator.

Installation and maintenance work may only be carried out when the system is depressurised (zero bar).

Make sure that the lines upstream and downstream of the trap are **not** under pressure!

Operation

MK 45-1, MK 45-2, MK 45 A-1, MK 45 A-2

MK 45-1, MK 45-2, MK 45 A-1 or MK 45 A-2 can be serviced (see **Maintenance**).

Thermostatic capsule

The factory setting of the regulating membrane enables the regulator to be steam-tight when closed and to open just before the pressure-dependent boiling temperature is reached.

Maintenance

MK 45-1, MK 45-2, MK 45 A-1, MK 45 A-2

GESTRA steam trap MK 45-1, MK 45-2, MK 45 A-1 and MK 45 A-2 does not require any special maintenance. However, if used in new installations which have not been rinsed it may be necessary to check and clean the trap / the regulating capsule.

Check steam trap

You can check the steam trap MK 45-1, MK 45-2, MK 45 A-1 and MK 45 A-2 for steam loss during operation using the ultrasonic measuring unit VAPOPHONE® or the test unit TRAPtest®.

We recommend that you apply the measuring probe tip at the lower part of the trap cover ③.

Should you detect any loss of live steam clean the trap and/or replace the capsule.

Clean / exchange capsule and nozzle insert

1. Observe note "Danger" on page 4.
2. Undo body screws ①. Remove cover ③ from the body ⑨.
3. Remove and clean capsule ⑤. Unscrew nozzle insert ⑥.
4. Replace capsule ⑤ in case of visible signs of wear or damage.
5. Clean body, internals and all gasket surfaces.
6. Apply heat-resistant lubricant to all threads and the seating surfaces of the nozzle insert and the cover (use for instance WINIX® 2150).
7. Screw in nozzle insert ⑥ and tighten with a torque of **90 Nm**.
8. Position capsule ⑤ onto the nozzle insert ⑥ and press evenly, such that the capsule snaps into place.
9. Replace gasket if there are visual signs of damage. Use the same cover.
Always replace gasket when using a new cover or the cover of another steam trap.
10. Put cover ③ onto the body ⑨. Tighten hexagon-head screws ① alternately and in several steps to a torque of **25 Nm**.

Clean / exchange strainer

1. Observe note “Danger” on page 4.
2. Unscrew sealing plug 12 and remove strainer 10.
3. Clean strainer, sealing plug and gasket seats.
4. Exchange strainer and sealing in case of visible signs of wear or damage.
5. Exchange gasket 8 if damaged.
6. Apply heat-resistant lubricant to the thread of the sealing plug (use for instance WINIX® 2150).
7. Install sealing plug 12 with gasket 11 and strainer 10. Tighten sealing plug with a torque of **120 Nm**.

Tools

- Spanner A.F. 16 mm to DIN 3113, form B
- Spanner A.F. 22 mm to DIN 3113, form B
- Spanner A.F. 30 mm to DIN 3113, form B
- Torque spanner 20 – 120 Nm to ISO 6789

Torques

Item	Designation	Torque [Nm]
6	Nozzle insert	90
1	Body screws	25
12	Sealing plug	120

All torques are based at 20 °C room temperature.

Spare Parts

MK 45-1, MK 45-2, MK 45 A-1, MK 45 A-2

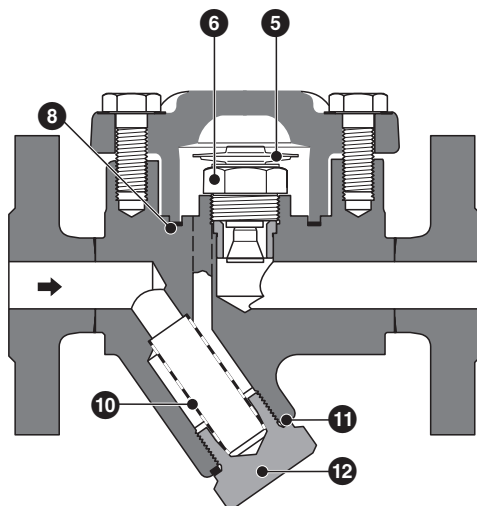

Fig. 8

Spare parts list

Item	Designation	Stock code	
		MK 45-1	MK 45-2
		MK 45A-1	MK 45A-2
13 8	Membrane regulator, complete 5N1	375 109	
	Membrane regulator, complete 5U1	375 111	
14 8	Membrane regulator, complete 5N2		375 110
	Membrane regulator, complete 5U2		375 112
10 11 12	Strainer set, complete	375 113	375 113
		375 382	375 382
5	Thermostatic capsule 5N1	376 165 ¹⁾	
	Thermostatic capsule 5U1	376 166 ¹⁾	
5	Thermostatic capsule 5N2		376 167 ¹⁾
	Thermostatic capsule 5U2		376 168 ¹⁾
8	Cover gasket ²⁾ 40 x 48 x 2, graphite	375 159	375 159
11	Plug gasket ²⁾ A 24 x 29, stainless steel	375 162	375 162

¹⁾ Packaged 10 per box. Contact your local dealer for smaller quantities.

²⁾ Minimum purchasing quantity 50 pcs. Contact your local dealer for smaller quantities.

Decommissioning



Danger

Risk of severe burns and scalds to the whole body!

Before loosening flanged connections, stuffing box unions or sealing plugs, make sure that all connected lines are depressurized (zero bar) and cooled down to room temperature (20 °C).

Disposal

Dismantle the equipment and separate the waste materials, using the specifications in the table “Materials” as a reference.

For the disposal of the equipment observe the pertinent legal regulations concerning waste disposal.



GESTRA

Agencies all over the world:

www.gestra.de

España

GESTRA ESPAÑOLA S.A.

Luis Cabrera, 86-88

E-28002 Madrid

Tel. 00 34 91 / 5 15 20 32

Fax 00 34 91 / 4 13 67 47; 5 15 20 36

E-mail: aromero@flowserve.com

Polska

GESTRA POLONIA Spolka z.o.o.

Ul. Schuberta 104

PL - 80-172 Gdansk

Tel. 00 48 58 / 3 06 10 -02 od 10

Fax 00 48 58 / 3 06 33 00

E-mail: gestra@gestra.pl

Great Britain

Flowserve GB Limited

Abex Road

Newbury, Berkshire RG14 5EY

Tel. 00 44 16 35 / 46 99 90

Fax 00 44 16 35 / 3 60 34

E-mail: gestraukinfo@flowserve.com

Portugal

Flowserve Portuguesa, Lda.

Av. Dr. Antunes Guimarães, 1159

Porto 4100-082

Tel. 0 03 51 22 / 6 19 87 70

Fax 0 03 51 22 / 6 10 75 75

E-mail: jtavares@flowserve.com

Italia

Flowserve S.p.A.

Flow Control Division

Via Prealpi, 30

I-20032 Cormano (MI)

Tel. 00 39 02 / 66 32 51

Fax 00 39 02 / 66 32 55 60

E-mail: infoitaly@flowserve.com

USA

Flowserve GESTRA U.S.

2341 Ampere Drive

Louisville, KY 40299

Tel.: 00 15 02 / 267 2205

Fax: 00 15 02 / 266 5397

E-mail: dgoodwin@flowserve.com

GESTRA AG

P. O. Box 10 54 60, D-28054 Bremen

Münchener Str. 77, D-28215 Bremen

Telephone +49 (0) 421 35 03 - 0

Fax +49 (0) 421 35 03 - 393

E-Mail gestra.ag@flowserve.com

Internet www.gestra.de

